

SLURRYSENSE

Self-cleaning sensor for ceramic slurry

Description

Rheonics SlurrySense is a self-cleaning technology for the SRV viscometer and SRD density and viscosity meter. The Rheonics CleanWave™ technology is integrated into SlurrySense ensuring a clean probe for continuous measurement in the ceramic drum with no need for manual cleaning. The CleanWave™ technology remove deposition. By either preventing deposition, or removing it at an early stage in its formation, tenacious deposition is avoided, and the probe remains clean of deposits.

Specifications

Probe Material

Stainless Steel 316L

O-Ring Material

FKM
FFKM (High Temperature)

Total Length

Customizable

Installation Accessories

Rheonics APC and Rheonics Mounting Base

Air Line Size

6 mm

Air Line Pressure

4 bar [60 psi]



Continuous Drum Slurry Monitoring

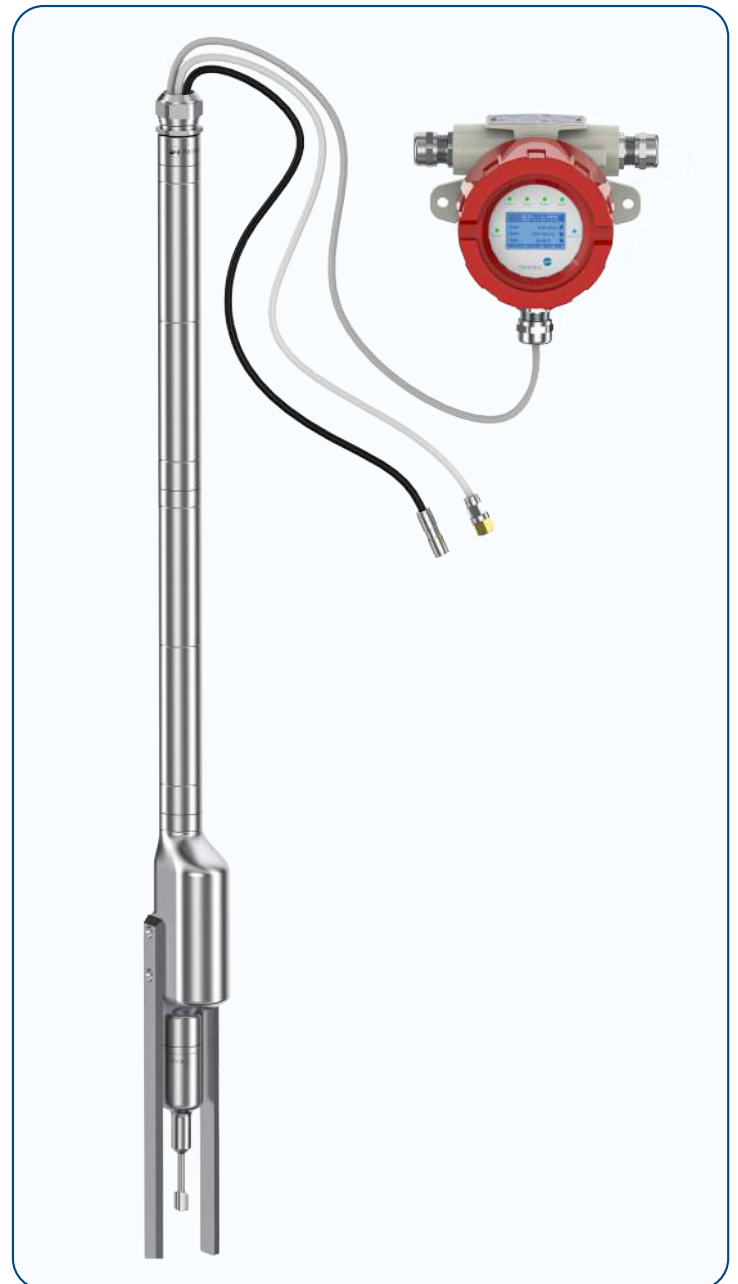

How does it work?

SlurrySense uses cleaning harmonics to ensure the slurry does not form deposits on the probe surface. SlurrySense integrates CleanWave™ technology into the probe body. Operating the vibrator causes fluid slip around the sensitive element of the probe, effectively preventing slurry deposition if run continuously.

The key to the SlurrySense with Cleanwave™ solution is operating the cleaning vibration at a much lower frequency than the measurement frequency of the Rheonics sensor. This ensures that the cleaning vibration cannot interfere with the measurement process, making it possible to clean continuously without interrupting the measurement process.

Advantages

- Sensor probe with self-cleaning harmonics
- Eliminates need for removal and cleaning
- Continuous monitoring without concern for deposits
- Measures reliably in the most deposition prone slurries
- Major step towards Industry 4.0 compliance
- Reduces reliance on plate-weight or efflux cup measurements

SlurrySense Installation Example

