

SlurrySense with CleanWave™

Product Launch Summary



Rheonics Solution

Process Challenge

Through our existing investment casting customers, a noted problem in shell rooms is the tendency for deposits to form on instrumentation in the slurry tanks. The existing Rheonics inline process density meters and viscometers resist deposit formation in many slurries, but with the most sticky slurries, the build up of these deposits can require cleaning protocols and checks to be added to already busy operator schedules.

Instrumentation that can operate fully hands-off is therefore desired to further automate critical continuous slurry density and viscosity measurements.

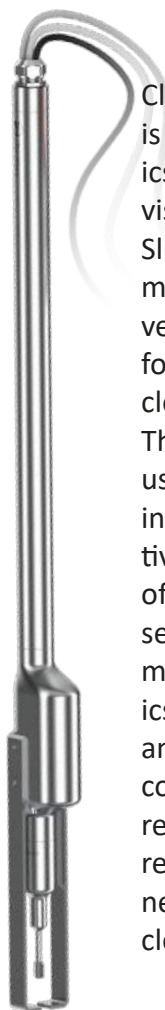

CleanWave™ Technology is integrated into Rheonics density meters and viscometers to create SlurrySense, a measurement probe that prevents deposits from forming using inbuilt cleaning wave vibrations. The cleanwave can be used continuously or intermittently to, respectively, prevent or slough off deposits. With the sensor probe cleanliness maintained, the Rheonics inline density meter and viscometer can continuously provide reliable consistency readings without the need for operator cleaning interventions.



Rheonics SlurrySense

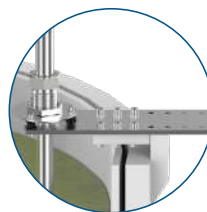

Rheonics APC and Mounting

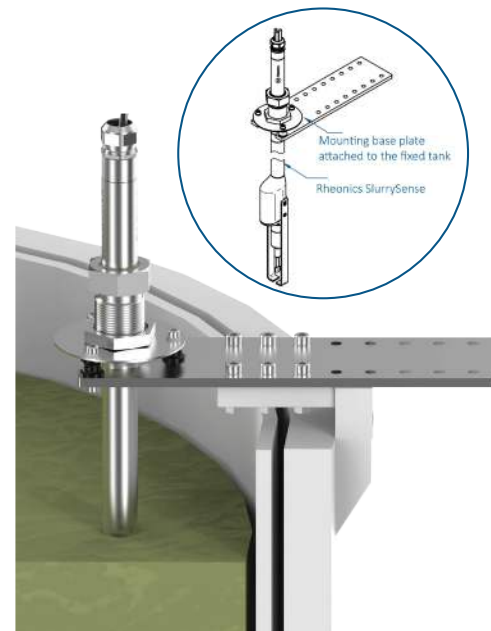

Value Outcomes

The tighter control of viscosity and density made possible with continuous inline measurements in slurry tanks ensures viscosity and solid weight deviations are caught early and product waste due to slurry consistency changes can be avoided. The consistent control of viscosity ensures uniform shell thickness, slurry adhesion to wax details, and surface finish. Shell strength, thermal conductivity, flexibility, and permeability are reliably steady when slurry consistency is dependable.

Sustainability goals are also addressed with SlurrySense viscosity and solids content control via improvements in mixing efficiency and reduction of product waste.



rheonics

Inline process density and
viscosity monitoring

rheonics GmbH

Zuercherstrasse 41
8400 Winterthur
Switzerland
+41 52 511 32 00

rheonics Inc.

3 Sugar Creek Center Blvd, Ste 100
Sugar Land, TX 77478
United States of America
+1 713 364 5427



www.rheonics.com
info@rheonics.com