

Rheonics SME Sensor Module Electronics

SME OPERATOR MANUAL

Inline Process Viscosity and Density Meters

Doc. ID: SME-OP-2409



GLOBAL SUPPORT

For Support, visit: <https://support.rheonics.com>

EUROPE HEADQUARTERS

Rheonics GmbH
Klosterstrasse. 19
8406 Winterthur Switzerland
Tel: +41 52 511 32 00

US HEADQUARTERS

Rheonics, Inc.
3 Sugar Creek Center Blvd, Ste 100
Sugar Land, TX 77478
United States of America
Tel: +1 713 364 5427

Website: <https://rheonics.com>
Support Portal: <https://support.rheonics.com>
Sales E-Mail: info@rheonics.com
Support E-Mail: support@rheonics.com

© COPYRIGHT RHEONICS 2024

No part of this publication may be copied or distributed, transmitted, transcribed, stored in a retrieval system, or translated into any human or computer language, in any form or by any means, electronic, mechanical, manual, or otherwise, or disclosed to third parties without the express written permission of Rheonics. The information contained in this manual is subject to change without notice.

TRADEMARKS

Rheonics is a trademark of Rheonics, Inc. Other product and company names listed in this manual are trademarks or trade names of their respective manufacturers.

Contents

1	Before you begin.....	5
1.1	About the manual	5
1.2	Contact.....	5
1.3	Who should use this document?	5
1.4	Warning.....	5
1.5	Nomenclature	5
1.6	Related Documentation	6
2	What’s in the box?	7
2.1	Scope of Delivery	7
3	Rheonics Sensor Module Electronics	8
3.1	SME-DRM (E1).....	8
3.2	SME-TR (E2).....	8
3.3	SME-TRD (E3)	9
3.4	SME-BOX (E4).....	12
4	Preparing the system	13
5	Sensor Wiring	14
5.1	Connecting and disconnecting wires to the terminal blocks on SME electronics	15
5.2	Connecting the sensor probe to sensor electronics	16
6	Powering the transmitter	17
6.1	Power supply specification	17
6.2	Examples	18
6.3	Industrial power supply	18
7	Communication Protocols	21
7.1	General Information	21
7.2	4-20mA (C1 - Default)	21
7.3	Modbus RTU (C2 - Default)	23
7.4	Serial USB (C3 - Default).....	23
7.5	Bluetooth (C5).....	23
7.6	Modbus TCP (C6).....	24
7.7	Ethernet/IP (C7)	24

7.8	HART (C8)	24
7.9	Profinet (C9)	24
7.10	IO-LINK,CC-LINK and much more coming	24
8	Sensor error status.....	25
9	Available units	26
10	RCP Software	28
11	Notes/Errata:.....	30
12	Revision and Approvals.....	31

1 Before you begin

1.1 About the manual

This manual provides information on the Rheonics SME. This document specifies all the device features and documents that the Rheonics SME supports in detail.

 This manual assumes that the following conditions apply: <ul style="list-style-type: none">• The sensor has been installed correctly and completely according to the installation instructions.• The installation complies with all applicable safety requirements.• The user is trained in government and corporate safety standards.
--

1.2 Contact

Contact the Rheonics team to help you with any inquiry.

For sales and delivery-related questions contact the Sales Team at info@rheonics.com

For installation, integration troubleshooting contact the Support Team at support@rheonics.com

1.3 Who should use this document?

The specification is designed to be a technical reference for Rheonics sensors End Users. This document assumes the reader is familiar with the transmitter and industrial instrumentation requirements and terminology.

1.4 Warning

The users should be trained in government and corporate safety standards that apply for their installation and use.

This installation manual is strictly for non-explosive atmospheres. If such installation is required, the user must refer to the Intrinsically Safe Installation Manual.

1.5 Nomenclature

Abbreviation (short form)	Full-term	Meaning
SRV	Symmetric Resonator Viscometer	Viscosity sensor
SRD	Symmetric Resonator Densitometer	Density and Viscosity sensor
DVP	Density Viscosity Probe	HPHT inline probe
DVM	Density Viscosity Module	HPHT inline module
RCP	Rheonics Control Panel	Software for data acquisition and configuration
SME	Smart Module Electronics	Sensor electronics

1.6 Related Documentation

You can find all product documentation on the USB storage device that is integrated in the sensor or was shipped with the sensors. You can also find them on the website at:

<https://rheonics.com/resources>

For more information on the sensor, refer to the following documents on Rheonics website. Contact the Rheonics Support Team if you cannot find a document online.

Title	Code	Description
SME Manual	SME-OP	Sensor Module Electronics Operator Manual
RCP Software Manual	RCP-OM	Rheonics Software Installation and User Manual
Communication Protocol Manuals	Various	Modbus TCP, Modbus RTU, HART, Profinet, Ethernet/IP, etc.
EX installation Sensor Manual	EX-IM	Installation of Intrinsically Safe Sensors Manual

2 What's in the box?

2.1 Scope of Delivery

The following items are delivered with Rheonics sensors:

- Electronic transmitter SME
- Rheonics sensor probe as ordered
- Protective Sleeve for the sensor probe.
- 24 Volts power supply (specify plug – US or EU). Depending on the powering method.
- Short power cable. Depending on the powering method.
- USB cable.
- Sensor cable.

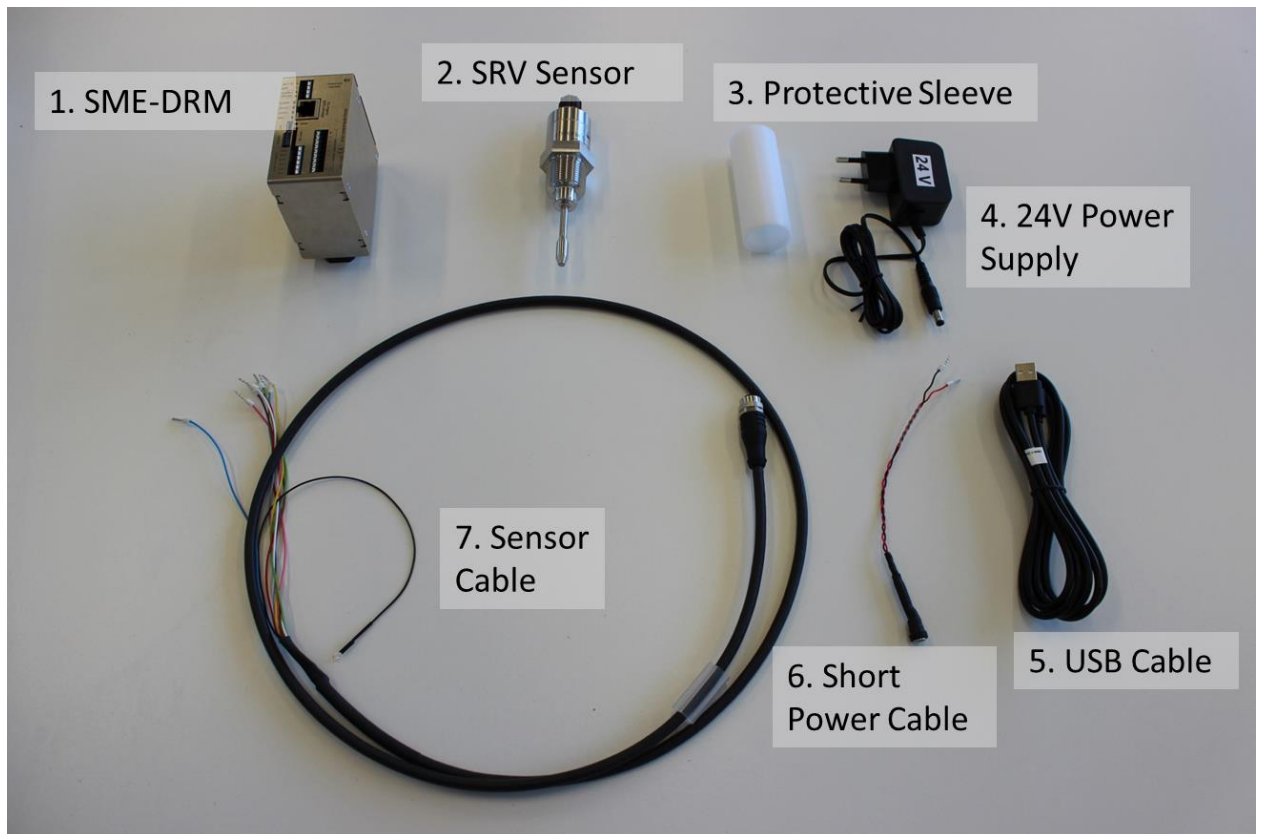

Figure 1. Identifying the items within the box

Notes:

- The items listed above may vary for your delivery and depends on the order code.
- Customer should inspect the goods upon arrival. In case of damage or missing items, contact Rheonics Sales Team at info@rheonics.com
- The Rheonics sensor probes have different variants, and the protective sleeve changes accordingly. The protective sleeve is meant to protect the probe's sensing element when stored or handled and should be removed for sensor operation.
- Rheonics offers different sensor cable variants and lengths. Review all variants [here](#).
- The sensor electronics SME has different variants. The image shows the SME-DRM. Review all variants on the electronics and communication page, [here](#).

3 Rheonics Sensor Module Electronics

Rheonics SME is the ultra-fast and robust module electronics of Rheonics sensors. It is connected to a sensor probe to read the signals from the probe, translate them to temperature, viscosity, and/or density, and transmit the data through multiple industrial communication protocols available by default or under request. The robust electronics make Rheonics sensors one of the market's fastest and most accurate sensors.

For the operation of Rheonics sensors, the electronics SME must be powered on and connected to the probe with the use of the sensor cable delivered by Rheonics. The SME and probe are paired together in factory, which means that the SME is not exchangeable, and should only be used with the probe it came with. If there is a requirement to connect an electronic with a probe different than the one it came with, contact Rheonics Sales Team.

Different SME variants are offered by Rheonics and are coded with prefix "E" in the order. These variants differ in the housing but have the same basic electronics unit inside.

3.1 SME-DRM (E1)

SME-DRM is designed for installation of the electronics on DIN rails and inside cabinets.

Some characteristics of the SME-DRM are:

- Housing material: Stainless Steel 304 (1.4301)
- Protection rating: IP20
- Weight: 0.2 kg (0.4 lbs)
- Installation: DIN rail inside cabinets



Figure 2 Rheonics SME-DRM

3.2 SME-TR (E2)

SME-TR has the electronics unit inside a blind solid enclosure. This is suitable for outdoors and indoors installations due to the higher ingress protection.

Some characteristics of the SME-TR are:

- Enclosure material: Aluminum with sprayed Polyurethane (PUR) coating
- O-Ring seal material: FKM
- Protection rating: IP66
- Weight: 1.7 kg (3.8 lbs)
- Ports: 3 ports of ½" NPT
- Installation: Outdoors and indoors



Figure 3. Rheonics SME-TR

3.3 SME-TRD (E3)

SME-TRD has the electronics unit inside a solid enclosure with a display. This is suitable for outdoor and indoor installations due to the higher ingress protection, and works as a local view for the operator to see the data in real-time. The display can show a maximum of three variables at the same time.

Some characteristics of the SME-TRD are:

- Enclosure material: Aluminium with sprayed Polyurethane (PUR) coating
- O-Ring seal material: FKM
- Protection rating: IP66
- Weight: 1.7 kg (3.8 lbs)
- Ports: 3 ports of ½" NPT
- Installation: Outdoors and indoors with local display

A multi-line LCD and LED lights are available on the SME-TRD display to monitor the sensor and communication status and visualize measured data instantly. Information on the LCD and LEDs are detailed next.



Figure 4. Rheonics SME-TRD

3.3.1 SME-TRD LED LIGHTS

SME-TRD display's LEDs are numbered next and their descriptions are detailed below.

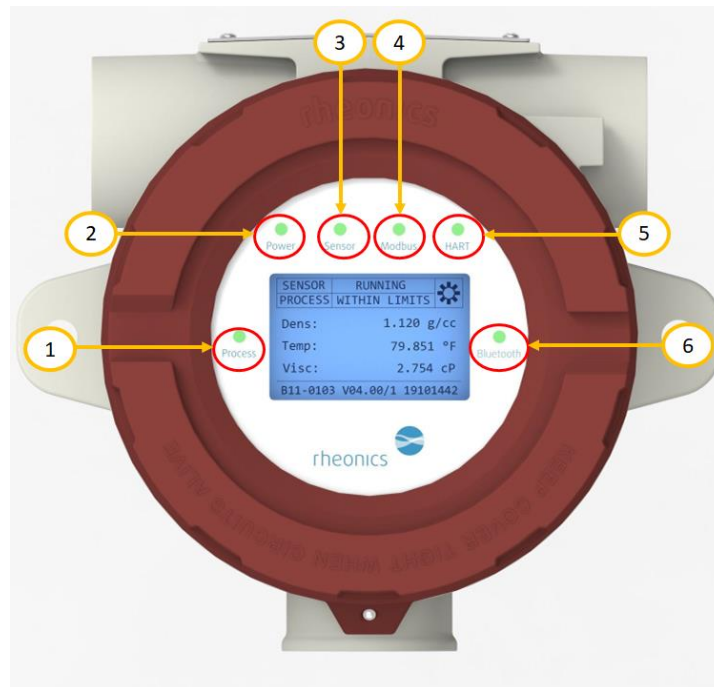

Figure 5. Rheonics SME-TRD - Display LEDs

1. **Process LED:** The LED light will operate on the following conditions.

Status	Description
Always Off	Sensor is in air
Always GREEN	Sensor is in fluid
RED	Unstable readings

Table 1. Process LED status

2. **Power LED:** Always green when the electronics is powered. Blinks red when only USB cable is connected but no power supply is active.
3. **Sensor LED:** Blinks green when in normal operation, it goes red when in error.
4. **Modbus LED:** Blinks green when Modbus communication is in operation. Always off when Modbus communication is not in use.
5. **HART LED:** The LED light will operate on the following conditions.

Status	Description
Always OFF	HART disabled
Always GREEN	HART enabled, idle state
Blinking GREEN	Bytes received; command not completed yet
Blinking RED	Bytes received; data corrupted
Always RED	Loop is open, no HART communication possible

Table 2. HART LED status

6. **Bluetooth LED:** The LED light will operate on the following conditions

Status	Description
Always OFF	Bluetooth disabled
Always BLUE	Bluetooth enabled
Blinking BLUE	Bluetooth communication is active

Table 3. Bluetooth LED status

3.3.2 SME-TRD WARNING AND ERRORS

The SME Display contains the following information.

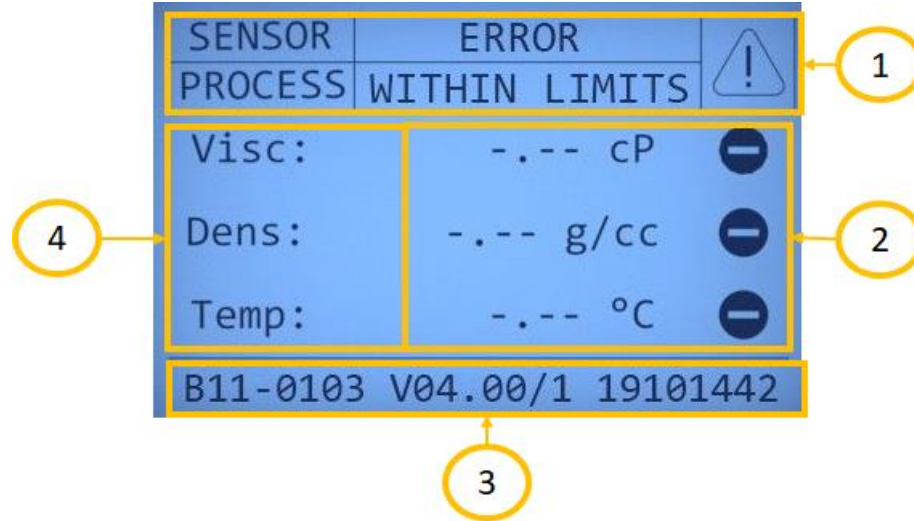

Figure 6. SME-TRD display parameters and sensor information.

1. **Sensor and Process:** Sensor (first) line can display the following status.

Status	Description
Running	Sensor readings are normal
Error	Sensor configuration issue
Unstable	Not reliable readings
Unlocked	The sensor is not locking properly to a measurement value.
Unavailable	Communication between electronics and display is not available

Table 4. Sensor line

Process (second) line can display the following status.

Status	Description
Out of range	Sensor readings are outside the measuring range
Within limits	Sensor readings are inside the measuring range

Table 5. Process Line

2. **Parameter value:** Each line will display the value and unit used. Additionally, a status is shown at the right which displays if there is an issue with that specific parameter.

3. **Sensor data:** This line displays information like the sensor serial number, FW version and IP address.
4. **Parameter name:** This section displays the parameters' name currently shown on the display.

3.4 SME-BOX (E4)

SME-BOX is a device designed for tabletop, desktop, or laboratory setups. It has a touch panel industrial PC integrated to run Rheonics software directly there without the use of an additional PC. Some characteristics of the SME-BOX are:

- Dimensions: 365 x 280 x 220 (mm) [14.4 x 11 x 8.7 (inch)]
- Power Input: 110 / 220 V AC
- Power consumption: max. 100W
- Total Weight: 8.1 kg (17.9 lb)
- Operating temperature: Max 65°C/150°F ambient
- Communication interface: 2x USB, 1x Ethernet, 1x HDMI, 1xRS485, 1x Wi-Fi
- Sensor Connection: M12
- Computer OS: Windows 10



Figure 7: Rheonics SME-BOX

4 Preparing the system

The sensor measurement system consists of two components: 1. SR Probes and 2. SME transmitter (Electronics unit)

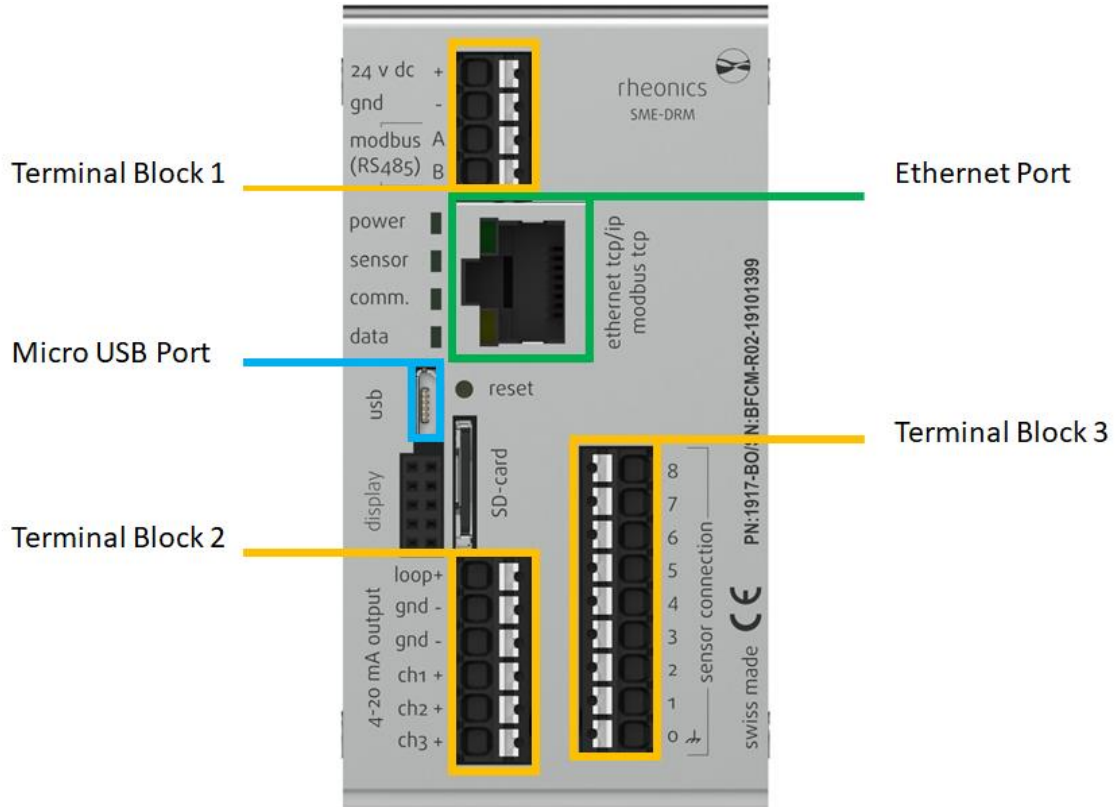

Figure 8. SME Transmitter (Electronics unit)

Rheonics sensor cables uses a ferrule with a pin length of 8mm and diameter of 1mm. The terminals of the [SME-TR/TRD](#) are rated for wires of 0.2 - 1.5 mm² i.e. AWG 24 - 16.

Terminal Block 1: Used for powering the electronics with a 24V DC power supply and for Modbus RTU communication with its RS485 port.

Terminal Block 2: Used for 4-20mA outputs, Rheonics offers 3 analog output channels that are configurable by the user.

Terminal Block 3: Used to connect to the sensor probe through the sensor cable.

USB Port: A port available for the sensor configuration and communication through a USB cable.

Ethernet Port: An Ethernet port is available for the sensor configuration and communication through an Ethernet cable.

5 Sensor Wiring

The figure below shows the typical connection of the SRV sensor, including the SME electronics and the sensor probe. These devices are connected using the sensor cable included in delivery, the physical connection on the probe is with an M12 8-pin female A-coded connector.

The sensor electronics should be powered with 24V DC. Fuses are recommended to safeguard the sensor electronics.

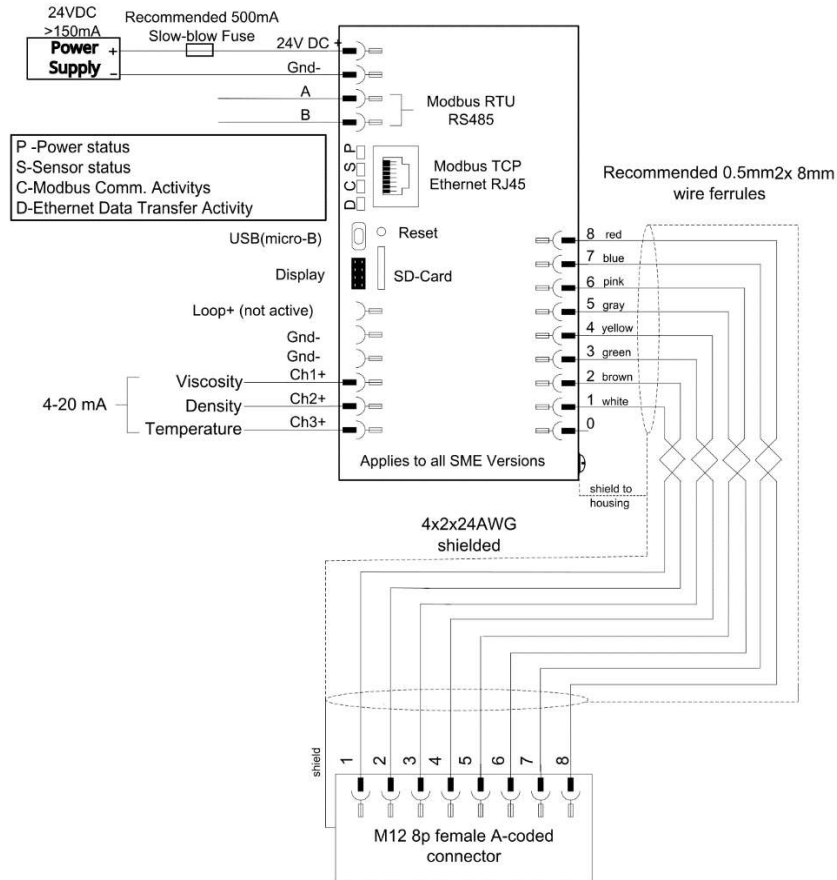

Figure 9: Rheonics sensor standard wiring.

Sensor supports multiple analog and digital communication interfaces and protocols. Refer to the communication manuals for details on each of the protocols and use. To download wiring drawings visit the Support Article: [Sensor electronics \(SME\) - Wiring drawing.](#)



ATTENTION: The sensor wiring shown above is not valid for intrinsically safe installations of an EX-certified SRV sensor in hazardous environment locations. Visit the correct manual at <https://rheonics.com/resources/manuals/>.

5.1 Connecting and disconnecting wires to the terminal blocks on SME electronics

The SME electronics has terminal blocks for the power input, sensor cable (8 wires), 4-20mA output signals (Ch1 also used for HART 2-wire communication), and Modbus RTU. Care should be taken to avoid damage by using excessive force while connecting and disconnecting wires to the terminal blocks.

The recommended wire gauge for the SME electronics is 0.5 mm² or 20 AWG. All wires connected to the SME should be crimped, 8 mm diameter crimps (white ferrules) are recommended. The sensor cable needs 8 wires with the correct ferrule for installation as shown in next Figure.

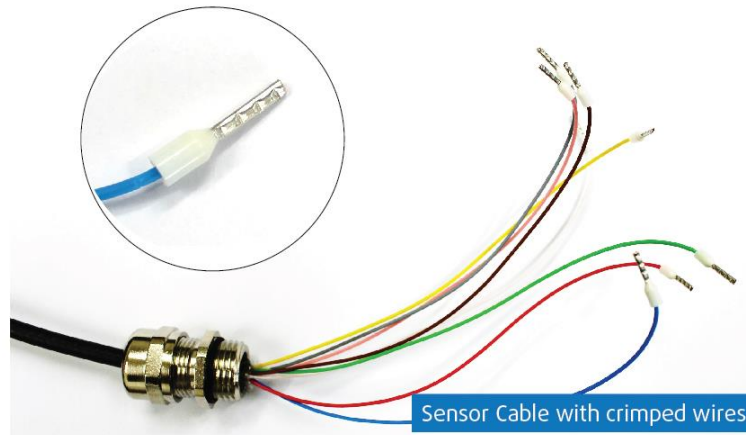

Figure 10: Sensor cable with crimped wires.

To connect wires to the SME, insert the crimped end in the correct port on the terminal block till it clicks firmly in place and cannot be pulled out when tugging on the wires (do not tug on the wires with a lot of force as that may damage the terminal block).

To disconnect the sensor wires, press the white tab for that specific port with a small flat screw driver as shown in the picture below where the user is removing wire connected to port 1. While pressing on the white part, pull out the cable connection with the other hand.

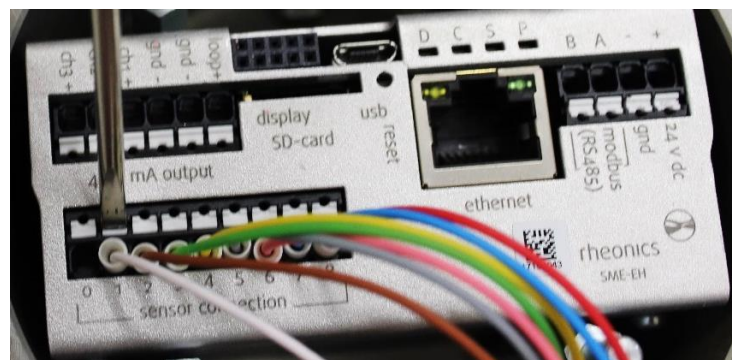

Figure 11: Disconnecting a wire from SME.

Review more on this article: [Cabling best practices](#).

5.2 Connecting the sensor probe to sensor electronics

The sensor is connected to the transmitter electronics by a sensor cable. Follow the color code table below to connect the correct wires from the sensor cable to the sensor connection terminal strip on the transmitter. The leads are delivered with crimped ends; cable can be shortened if needed, but ferrules should be crimped onto the stripped ends.



Figure 12: Sensor cable connection to the sensor electronics.

Wire Color	Sensor connection terminal #
Red	8
Blue	7
Pink (Rose)	6
Grey	5
Yellow	4
Green	3
Brown	2
White	1
---not connected---	0

Table 6. SME terminal for sensor cable wires



ATTENTION: The wiring color order shown in the table above is not valid for intrinsically safe installations of an EX-certified SRV sensor in hazardous environment locations. Visit the correct manual at <https://rheonics.com/resources/manuals/>.

6 Powering the transmitter

The sensor power consumption is as follows:

- Voltage required: 24V DC
- Voltage range acceptable: 18-36V DC
- Current required (min): 120 mA
- Current recommended: 200 mA or higher
- Power required (maximum): 3W
- Power recommended: at least 5W
- Fuse (if required) rating: >500 mA Slow-blow fuse

Power input terminals are labeled with 24 V DC + and – GND. Connect a 24V DC supply to the power input terminals on the transmitter.

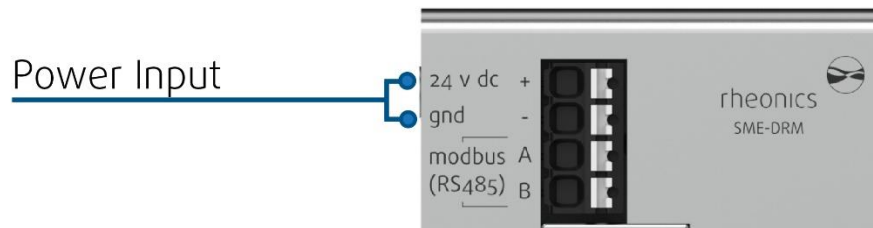

Figure 13: Power terminals in SME electronics.



It is important to avoid ground loops in the setup/plant where the SME is used. Ground loops can lead to excessive currents on the ground/return wire of the SMEs 24V power supply which can damage the unit.

To prevent this, we strongly recommend that the SME is powered by a separate 24V power supply with galvanic separation. Otherwise, the SME might be permanently damaged.

Review SME wiring diagram at [Sensor electronics \(SME\) – Wiring drawing](#).

6.1 Power supply specification

When selecting a power supply to power the Rheonics sensors, select one with the following ratings:

- Voltage output: 24V DC
- Power rating: 5W or higher
- Current rating: 200 mA or higher

Often power supplies are available that meet the local regulatory approvals and can take all of the following inputs: DC, AC, Single-phase, 2-phase, and 3-phase.



Rheonics sensors can be configured over USB but the sensor will NOT make any measurements over USB supplied power. For operation (factory floor or in lab), it is recommended to power the sensor using a galvanically separated, certified power supply from a reliable source. Check power supply to ensure you get the required voltage and current without significant noise.

6.2 Examples

We show below some examples of industrial power supplies that can be used with the sensor. This is by no means an endorsement of any specific brand. Any adequately rated power supply from reputable manufacturers will give you a stable, noise-free, and safe power supply for your sensor operation.

It is the customer's responsibility to ensure that the power supply that is sourced meets the local and national requirements for their installation.

Rheonics does not sell power supplies due to the varying global connector and power ratings. However, the power supplies mentioned below are quite universally available or have suitable alternatives.



A fuse is not necessary from the DC converter but if you plan to use one then a 200 mA 24V fuse is sufficient. The device has a maximum power input requirement of under 5W.

6.3 Industrial power supply

Applications:

- Used in enclosures/cabinets
- Used for powering sensors in the plant (Industrial power supplies provide a higher level of reliability in connection compared to power adapters connected to power strip)
- Single, 2- or 3-phase power supply can be used which have a DC output of 24V DC

These typically tend to be DIN rail mount units as shown below:

- **DIN rail mounted:** This power supply unit is designed to be easily mounted on a DIN rail, providing a secure and standardized way to install it within an electrical enclosure



Figure 14. Din rail mounted power supplies [[Din rail power supply-Siemens](#)]



DISCLAIMER

Rheonics is not endorsing this product, users should use it at their own risk, and it merely serves for informational and illustration purposes; no rights can be derived from its contents.

- **Switching Power Supply (SPS):** an electronic power supply that uses a switching regulator to convert electrical power efficiently. It differs from traditional linear power supplies in its methodology of voltage regulation and power conversion.



Figure 15. Switching power supply (SPS) [[Mean Well Switching power supply](#)]



DISCLAIMER

Rheonics is not endorsing this product, users should use it at their own risk, and it merely serves for informational and illustration purposes; no rights can be derived from its contents.

- **Power Adapters (Wall mount style):** These can be directly mounted on the wall outlet. They will need an adapter to connect from the plug on the adapter to the SME. Alternatively, the jack can be removed and the wire ends can be directly used (recommended to use a crimped connection on the ends).



Figure 16. Power adapters (Wall mount style) [3]



DISCLAIMER

Rheonics is not endorsing this product, users should use it at their own risk, and it merely serves for informational and illustration purposes; no rights can be derived from its contents.

- **Benchtop Power Supply**
These are versatile and often have a selection of power outputs. The power output must be set to 24V DC. A lower voltage may not be sufficient for the sensor to operate and a higher voltage can damage the SME electronics.

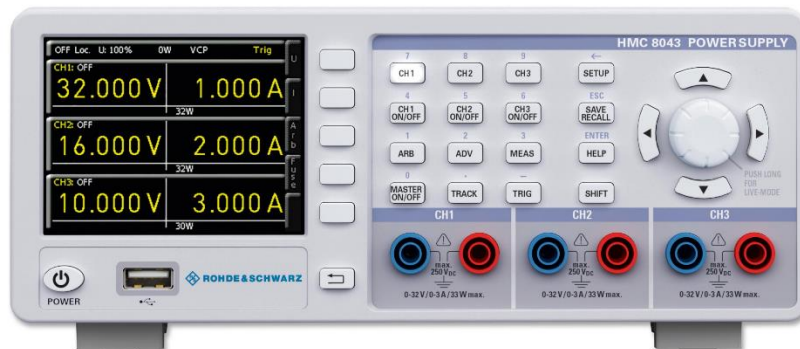

Figure 17. Benchtop power supply [[Bench Power supply - Rohde&Schwarz](#)]



DISCLAIMER

Rheonics is not endorsing this product, users should use it at their own risk, and it merely serves for informational and illustration purposes; no rights can be derived from its contents.

7 Communication Protocols

7.1 General Information

Rheonics sensors are extremely easy to integrate into user's application or projects, since the sensors have several industrial communication protocols available.

Rheonics provide extensive support resources on each communication protocol to enhance flexibility and convenience for our customers across diverse industries. **Some integration protocols come with the sensor by default, while others should be requested during sensor order.** Review all protocols at <https://rheonics.com/electronics-and-communication/>. For the latest communication manuals on each protocol visit <https://rheonics.com/resources/manuals/>.

7.2 4-20mA (C1 - Default)

Rheonics sensors have 3 channels for 4-20 mA signals, as indicated in the next Figure 15. The 4-20mA signals are used mostly for the simplicity of using just 2 wires to transmit the sensor readings to an external device. However, users should be aware that these analog signals are not overly susceptible to noise and are accurate only under certain field conditions.

By default, the SRV outputs the viscosity, density, and temperature parameters through the 4-20mA ports, but these are customizable from the RCP, Rheonics Software.

Check these support articles: [4-20 mA](#) for more information.

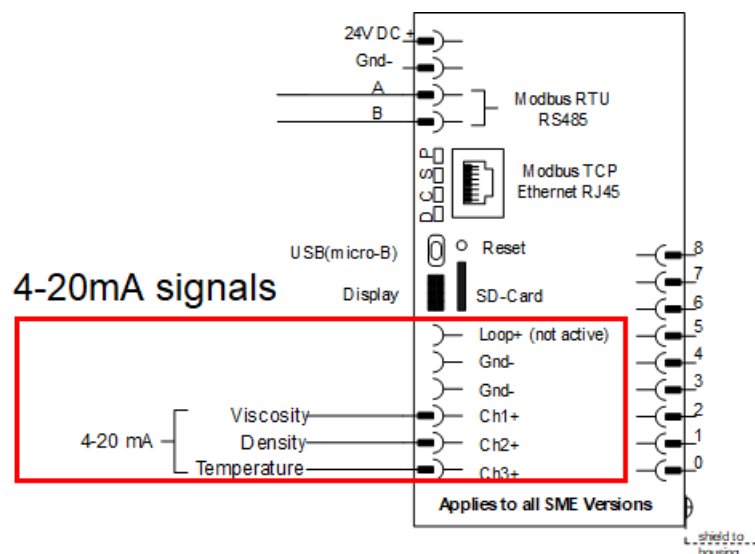

Figure 18. 4-20mA outputs available in the SME

7.2.1 Wiring diagram for SME electronics and 4-20mA

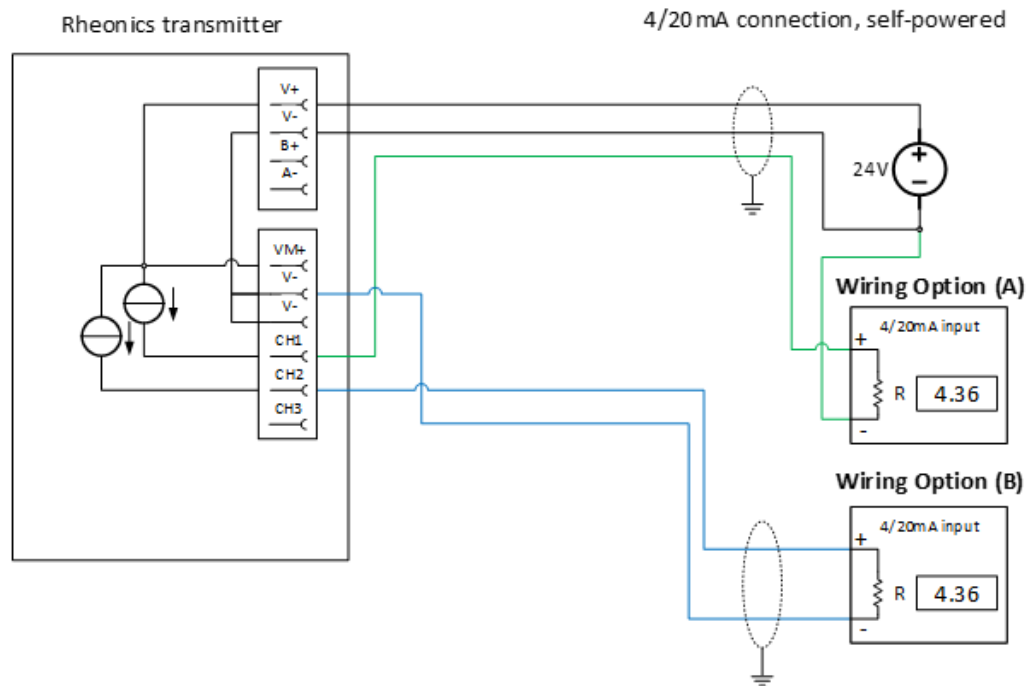

Figure 19. Wiring diagram for Rheonics SME

7.2.2 Electrical parameters

Load impedance: 0 to 720 Ohms

Output range: 4-20mA (3.5mA error)

Galvanic isolation: none

Wiring Option (A)

- Connect the positive terminal of current input module to the desired channel terminal of SME device
- Connective negative terminal of current input module to negative power supply terminal used for SME device

Wiring Option (B)

- Connect the positive terminal of the current input module to the desired channel terminal of SME device
- Connect the negative terminal of the current input module to V- terminal of SME device

7.2.3 Is the Rheonics SME a passive or active device?

Rheonics SME is considered a 4-wire transmitter, in other words, it is an active sensor transmitter. Passive sensor devices are in general 2-wire transmitters required to be powered by external power supplies, instead, active sensor devices will use the same power supply from the transmitter to create a controlled analog output.

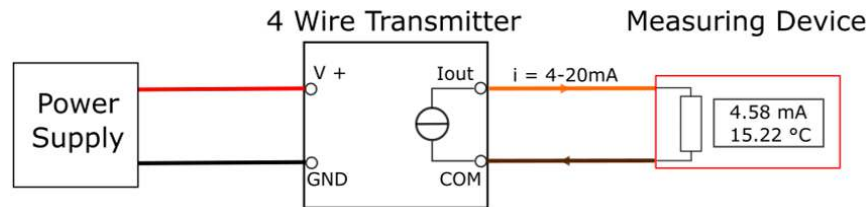

Figure 20. 4-wire transmitter, a block diagram of the Rheonics SME.

An active analog output incorporates circuitry to actively drive and control the output signal. It has the following characteristics:

- If a test is done by measuring the analog output with the device powered on, we are going to receive a voltage output or a current output different from zero.
- The output from the Rheonics sensor must be connected to a sinking input from a PLC.



- **The 4/20mA outputs are not galvanically isolated. It is not recommended to route the 4/20mA to off-site locations if the corresponding 4/20mA input does not provide galvanic isolation.**
- **Only for Ex Sensors. Power Input: 240V Maximum AC Single Phase, this is exclusive for Ex sensor configuration and would be the best to protect the zener barriers used in the configuration, only single phase power supplies should be used.**

7.2.4 What can go wrong with 4-20mA loops?

Many factors can lead to a malfunctioning 4-20mA loop. The problem can be caused by a poor selection of power, wiring, or loop devices. If the loop does not appear to work properly, it is recommended that you first check the power and wiring. Check this support article: [What can go wrong with 4 - 20mA loops ?](#)

7.3 Modbus RTU (C2 - Default)

Rheonics SME offers Modbus RTU over an RS485 interface. This protocol gives the user access to multiple parameters read by the sensor in real time. The data over Modbus is exchanged in the form of registers. This interface allows interoperability between devices from different manufacturers.

The Modbus RTU communication is established with Rheonics sensors through two wires labeled on the sensor electronics, as shown in Figure 11. Check these support articles for more information on the integration and registers [Modbus RTU \(RS-485\)](#) and review the manual "[MRTU-OP](#)" on Rheonics resources webpage.

7.4 Serial USB (C3 - Default)

All Rheonics sensor electronics (SME) come with a standard USB port for initial configuration and data monitoring. Check these [USB Communication](#) for more information about communication over USB with Rheonics Sensors.

7.5 Bluetooth (C5)

Rheonics support Bluetooth LTE 4.0 in the SME-TRD device only. By using this technology, the sensors can transmit measured data wirelessly. Rheonics provides various software for Windows,

Linux, MacOS, iOS, and Android devices to connect the sensor over BLE. Contact Rheonics or visit the [Support Portal](#) for more information.

7.6 Modbus TCP (C6)

The Rheonics SME offers Modbus TCP protocol over the Ethernet interface. This protocol gives the user access to multiple registers that contain the parameters read by the sensor.

Using Modbus TCP, allows the user to connect the sensor to the Ethernet TCP IP network through an Ethernet cable with Client-Server communication. Check Rheonics support articles for more information on the integration and registers [Modbus TCP \(Ethernet\)](#) and review the manual “[MTCP-OP](#)” on the Rheonics resources webpage.

7.7 Ethernet/IP (C7)

All Rheonics SME variants can be ordered with Ethernet/IP. This communication protocol enables the fast delivery of extensive data from Rheonics SME sensors to external devices, like Allen-Bradley PLCs, through the SME Ethernet Port. Rheonics have extensive expertise with Ethernet/IP, hence comprehensive guidelines can be found on Rheonics Support Portal to ensure an easy and effective. Check these support articles [Ethernet/IP](#) and review the user manual on the Rheonics webpage.

7.8 HART (C8)

All Rheonics SME variants can be ordered with HART. Using the HART protocol, Rheonics sensors deliver 4 parameter readings as digital data, which are PV, SV, TV, and QV. By default, the output parameters are the following:

SRV default configuration	
PV	Viscosity
SV	Density
TV	Temperature
QV	Sensor Status

Table 7. SRV HART Parameters

Check these support articles on [HART](#) and review the manual on the Rheonics resources webpage.

7.9 Profinet (C9)

All Rheonics SME variants can be ordered with Profinet. Using Profinet, the Rheonics Sensors can transmit real-time data at 100 Mbps in full duplex communication through the SME Ethernet Port, resulting in improved operational performance, precision, and system integration. Check these support articles [PROFINET](#) and review the manual on the Rheonics webpage.

7.10 IO-LINK,CC-LINK and much more coming ...

Contact Rheonics Support Team for information on additional communication protocols.

8 Sensor error status

All Rheonics sensors (SRV, SRD, DVP, DVM and others) for inline viscosity and density monitoring have inbuilt status. These status bits can be used over digital communication channels to understand when the sensor is operating correctly and when there is an issue.

Bit	Hex	Name	Comment
Bit 0	0x0001	PLL frequency mismatch	The PLL frequency does not match the sensor frequency. Derived from the ASB string (E10)
Bit 1	0x0002	PLL not locked	The PLL is not locked. Derived from the ASB string (E01)
Bit 2	0x0004	PLL lock incorrect	The PLL has locked on a wrong frequency. Derived from the ASB string (E02)
Bit 3	0x0008	ASB communication error	
Bit 4	0x0010	Temperature sensor failed	The temperature sensor has failed. Derived from the ASB string if temperature is -273.0
Bit 5	0x0020	Sensor too hot	If temperature is above the hardcoded physical temperature limit.
Bit 6	0x0040	ASB communication error	
Bit 7	0x0080	Serial Changed	
Bit 8	0x0100	Status not clean	Sensor is not clean.
Bit 9	0x0200	Status in Air	Determines if sensor is in air
Bit 10 -15	Unused		

Table 8. Sensor error status

9 Available units

Rheonics sensors output different measurements which are referred to as parameters. The units for each parameter can be found in table 4. Check this support article: [Measurements](#)

Parameter	Unit	Description
Dynamic Viscosity	cP	Centipoise
	Poise	Poise
	Reyn	Reyn
	Pa.s	Pascal-seconds
	mPa.s	milipascal-seconds
Kinematic Viscosity	mm ² /s	
	m ² /s	
	in ² /s	
	cSt	centistoke
	St	stoke
	SUS	Saybolt universal seconds
Density	g/cc	grams per cubic centimeter
	Kg/m ³	Kilograms per cubic meters
	lb/ft ³	pounds per cubic foot
	lbm/gal	pound mass per gallon
	lbs/gal	pounds per gallon
	ppg	pound per gallon
	pptf	psi per thousand feet
	slug/ft ³	slug per cubic foot
Viscosity	η	Viscosity
Temperature	°F	Fahrenheit
	K	Kelvin
	°C	Celsius degrees
Temperature	ref _{xx} ^{°y}	
Concentration	SG	Specific gravity
	rho	ρ
	°API	API gravity
	°Bé	°Baumé
	°Bx also works	°Brix
	°P	°Plato
	%wt/v	% weight / volume
	% v/v	% volume / volume
	% vol	% volume ethanol
Pressure	bar	Pressure
	psi	Pressure
Flow	m ³ /s	Flow
	sccm	Flow
	gpm	Flow
pH	pH	pH
Volume	m ³	Volume

	gal	Volume
standard temp and pressure	STP	standard temp and pressure
Reference temp	Tref	Reference temp
refractive index	nD	refractive index
% by weight	%wt	% by weight
% by volume	%Vol	% by volume
concentration molar	mol/m ³	concentration molar
alcohol	ALC	alcohol
ethanol	EtOH	ethanol
Frequency	Hz	Frequency

Table 9. SME available units

10 RCP Software

The Rheonics Control Panel (RCP) is a software that allows the user to get the full potential of Rheonics sensors. The software is used for sensor configuration, measurement visualization, download of historical log files, and more. The software is included in the USB storage delivered with the sensor. If that is not the case, or you do not have the USB stick anymore, contact the Rheonics Support Team and share the sensor serial number S/N to request the software.

Review the RCP Software Manual for complete instructions on installation and use. The software is included in the USB storage delivered with the sensor.

THE SME ELECTRONIC MUST BE CONNECTED TO THE COMPUTER WITH THE USB CABLE
AND POWERED UP CORRECTLY TO ESTABLISH THE FIRST COMMUNICATION WITH THE RCP

To start using the sensor and the Rheonics software, the following should be done:

1. Connect the sensor probe to the SME transmitter
2. Connect the power supply to the transmitter
3. Connect the micro-USB cable to the transmitter electronics. Connect the other end to a free USB port on the computer.
4. Run the Rheonics Control Panel software. The Rheonics Control Panel application is opened from the PC's start menu.
5. Go to the Settings Tab and select the correct USB Port to detect the sensor by clicking in the button "Apply". Wait for the Status LED to turn green.
6. Go to the Measurements Tab to visualize the readings in real time.

Find further steps on the RCP Software Manual and on Rheonics articles at [RCP – Rheonics Control Panel - Articles](#).

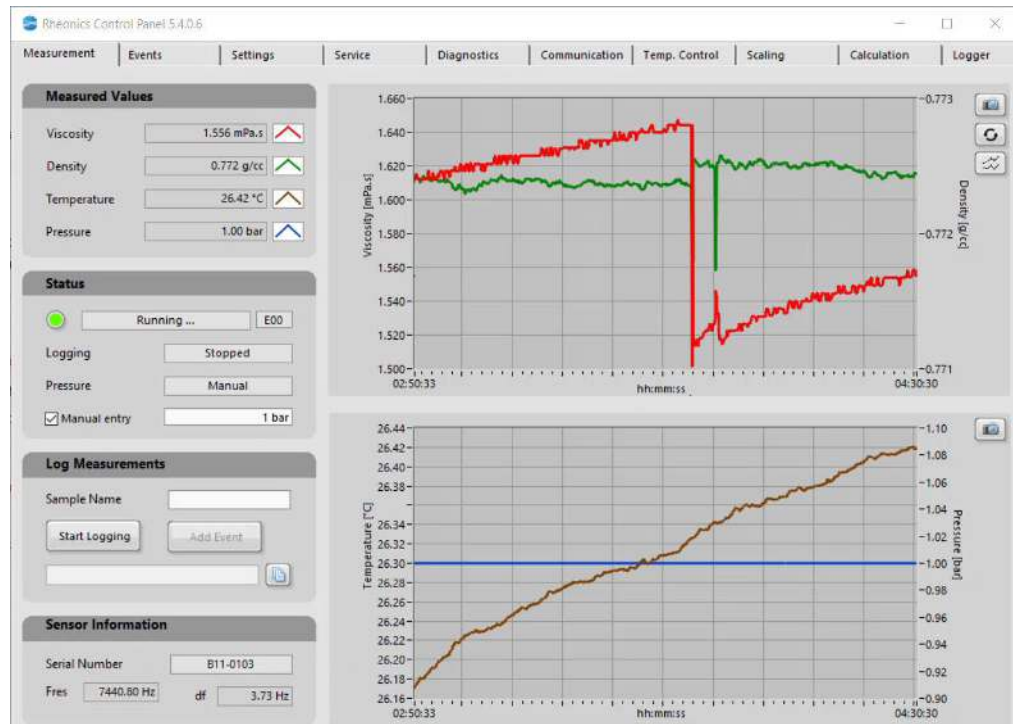

Figure 21. Figure 22: RCP Measurement Tab.

For help with the Rheonics Control Panel (RCP) and its settings, user can access through the software to the Help tab and click on RCP – Rheonics Control Panel Software manual or contact Rheonics Support Team at support@rheonics.com.

11 Notes/Errata:

12 Revision and Approvals

Version	Nature of changes	Approvals	Date
1.0	Original version		17.09.2024