

Tri-Clamp Ferrule Weldolet	
Order Code	WFT-15T-32A
Connection	Tri Clamp DN32
Norm	DIN 32676
Material	1.4404 (316L)
Includes	Clamp Seal
	Closure Clamp

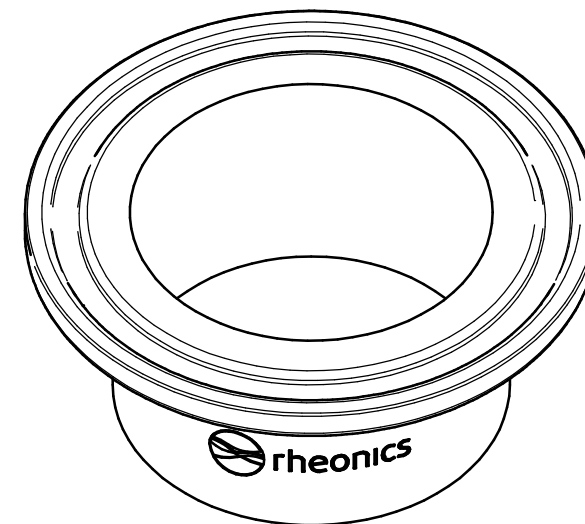

Units: mm  
[inch]

## WFT-15T-32A 1.5" Tri-Clamp Ferrule

This drawing remains property of rheonics. It may be neither copied nor informed to third persons or competitors without our approval. ( 2 paragraph 1 fig.7 copyright act of 9th Sept. 1965)

Protected by US and International patents granted and pending

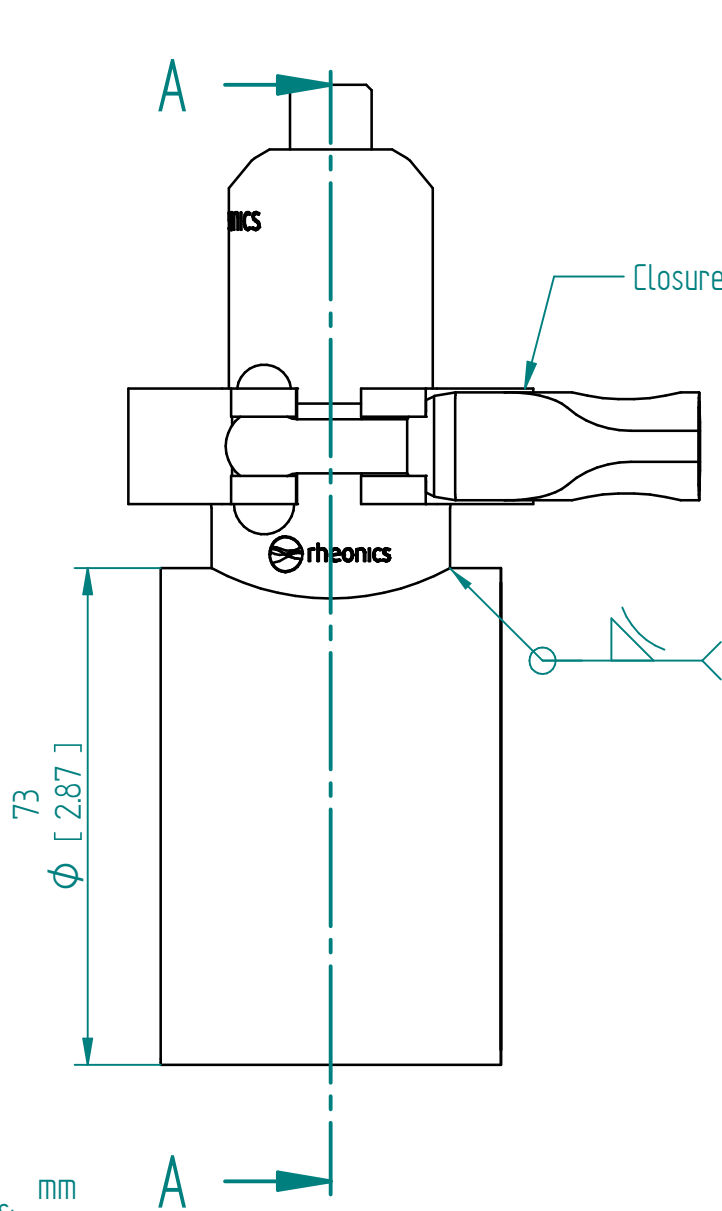

SRV-X3-15T

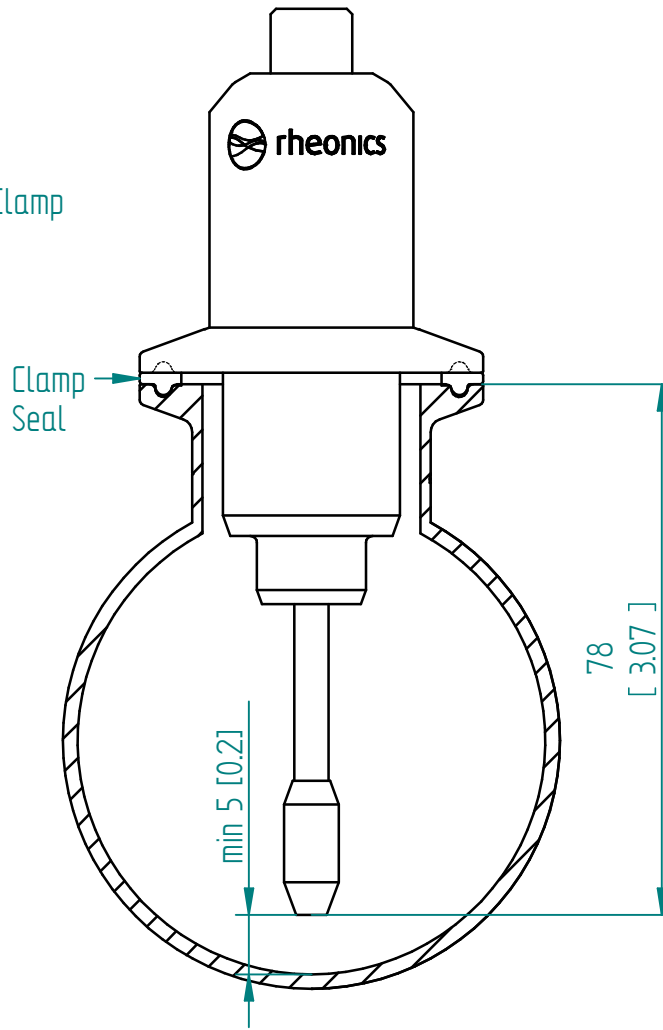

SRD-X3-15T

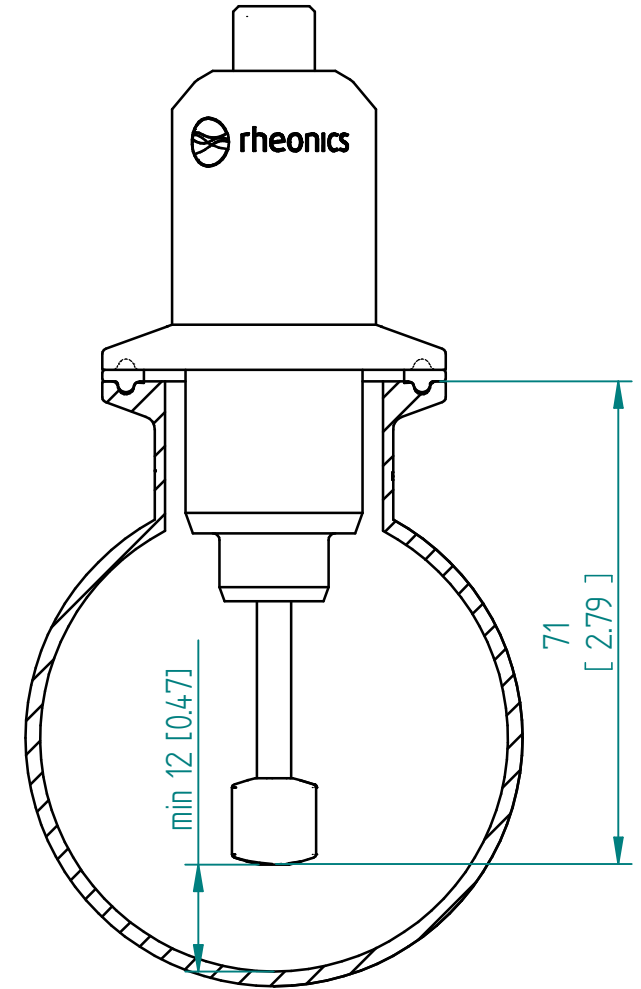

Units: mm  
[inch]



inline process  
density and viscosity  
monitoring

# Installation drawing WFT-15T-32A

This drawing remains property of rheonics. It may be neither copied nor informed to third persons or competitors without our approval. ( 2 paragraph 1 fig.7 copyright act of 9th Sept. 1965)

Protected by US and International patents granted and pending