

SME	
Type	SME-TRD
Weight	1.7 kg [3.8lb]
IP-Rating	IP66
Power	24VDC
Ports	3x 1/2" NPT
Material enclosure	Aluminum with Sprayed Polyurethane (PUR) coating
Material o-ring	FKM

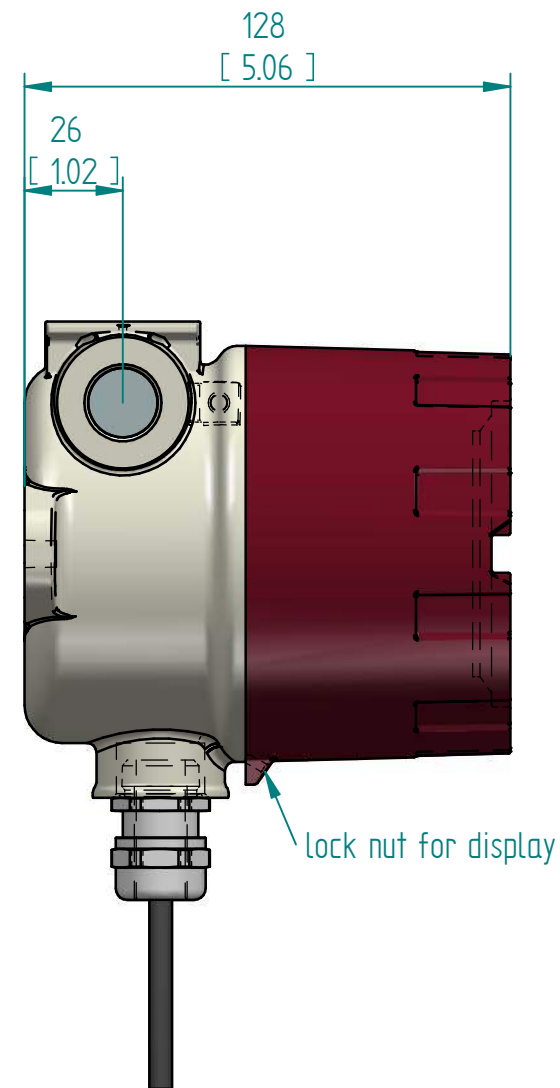
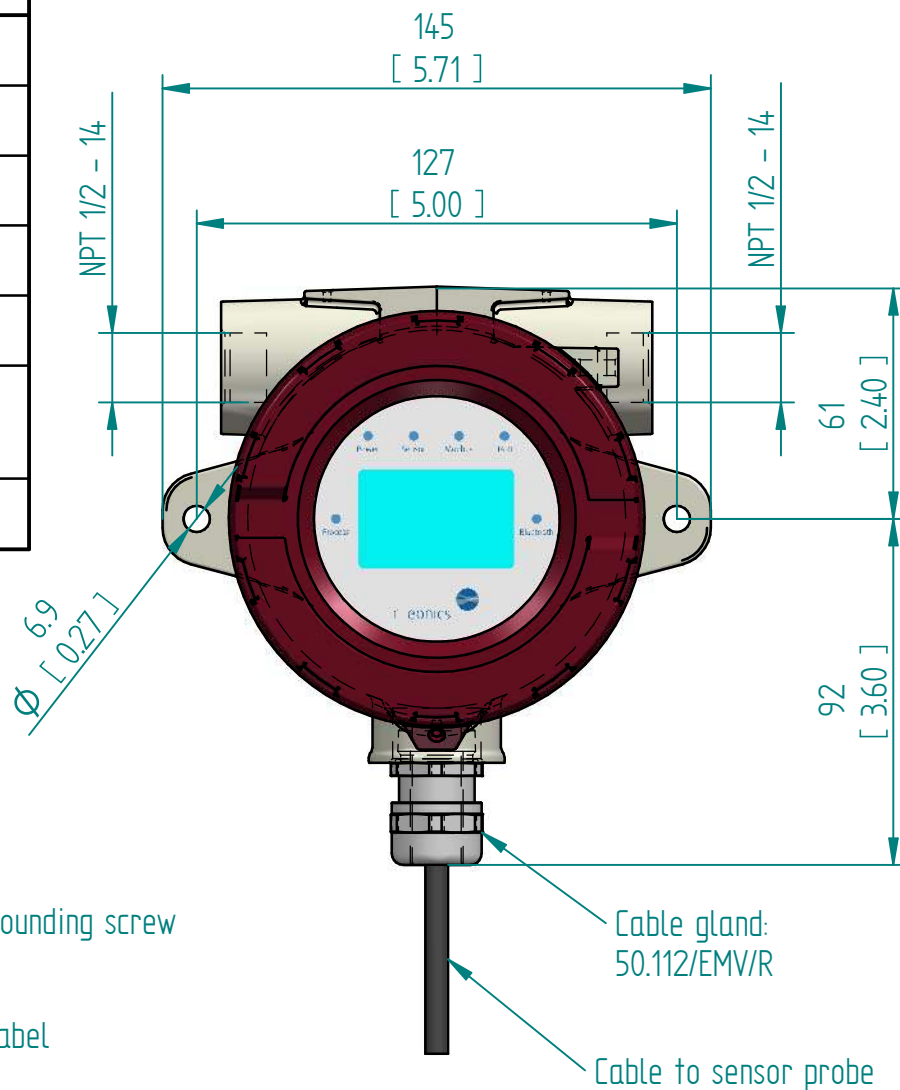
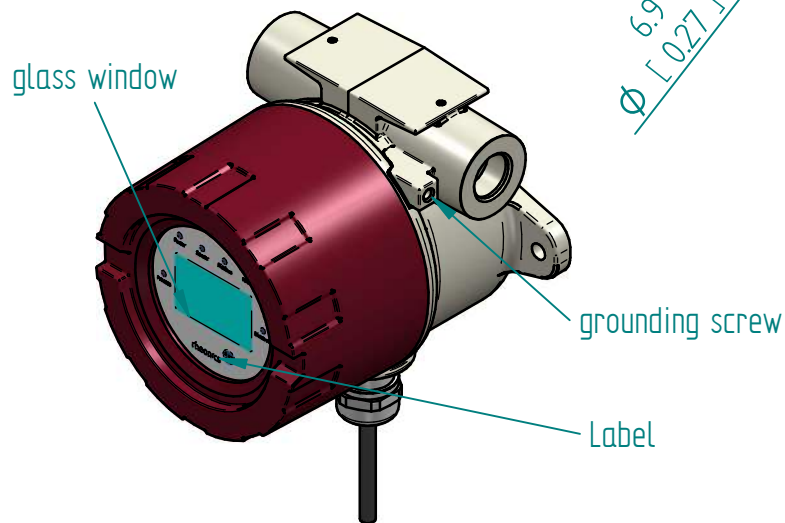

Units: mm
[inch]

For mounting, use
TMB-TRX : Transmitter Mounting Bracket

This drawing remains property of rheonics. It may be neither copied nor informed to third persons or competitors without our approval. (2 paragraph 1 fig.7 copyright act of 9th Sept. 1965)

rheonics 

inline process
density and viscosity
monitoring